

SOLUTIONS



***The Thirteenth
Annual***

**North American
Computational
Linguistics
Olympiad
2019**

www.nacloweb.org



Carnegie Mellon University
Language Technologies Institute



**Massachusetts
Institute of
Technology**

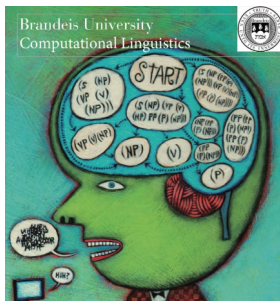

Yale University

**Invitational
Round**

March 7, 2019

Serious language puzzles that are surprisingly fun!

-Will Shortz, Crossword editor of The New York Times and Puzzlemaster for NPR

(I) The Afrihili Word Machine (1/1)

A.

English	Afrihili
machinist	afimadi
ships	imeli
presidents	ajamura
Flower	ature
Baker	amkamate
group of girls	omukazisini
date fruit	entindi
language	oluga
shoe	isabatu
king	omukama

B. Below are three more Afrihili words and three options for a likely translation of the word. Pick the most likely translation to be correct, and explain your choice.

1. imulenzi (a) fruit (b) boys (c) bridge **Answer: B**

Explain your choice: **Identical initial and final vowel => plural form. The only plural word is *boys*.**

2. aposino (a) baggage (b) classroom (c) parent **Answer: A**

Explain your choice: **The suffix *-sin-* is used to derive collective nouns. The only truly collective noun among these choices is *baggage*.**

3. iwelemase (a) book (b) library (c) librarian **Answer: C**

Explain your choice: **The *-ma-* infix is used to derive nouns of profession. The only noun referring to a profession is *librarian*.**

C. Describe what you have learned about the morphological structure of words in Afrihili.

On structure of nouns: Start and end with V. – 1 point

Inflectional morphology:

Singular form: Initial and final V differ. – 1 point

Plural formation: Final vowel replaces initial vowel of singular form. – 1 point

Derivational morphology:

Head of an organization (1): Final and initial vowel of root noun are reversed (1). – 2 pts

Nouns of profession (1): Infix *-ma-* (1) is inserted in penultimate position (1). – 3

Collective noun (1): Suffix *-sin-* (1) +final vowel of root noun (1). -- 3

Diminutive noun (1): Suffix *-nd-* (1) +final vowel of root noun (1). – 3

Examples provided to illustrate each of the above (3 points)

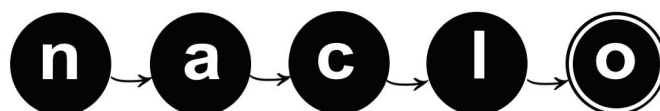

(J) Polish These Nouns (1/2)

Polish consonants are divided into *hard* and *soft* consonants, which correspond as follows:

hard **soft**

k c

g dz

r rz

hard **soft**

d dz

st śc

(N/A) sz

Note that **b** and **s** are hard consonants without a corresponding soft consonant; their soft equivalents are simply **b** and **s**, respectively.

Pluralization rules for nouns (in order of priority):

first, final **-a** is removed; **ó** → **o**; **CeC** → **CC**

if the noun ends in a **soft** consonant, add **-e**

otherwise, if the noun represents an **official** or a **leader**, add **-owie**

otherwise, if the noun represents a person:

 soften the last consonant of the stem

 add **-y** if noun ends in **-k, -g, -r**; **-i** otherwise

otherwise:

 add **-i** if noun ends in **-k, -g, -r**; **-y** otherwise

Pluralization rules for adjectives:

adjectives whose roots end in **-ki**: **-cy** for humans, **-kie** otherwise

adjectives whose roots end in **-Cy**: **-Si** for humans, **-Ce** otherwise (where S = softened form of C)

Adjectives come before nouns.

N1: Grammatically, loafers are considered nonhuman (due to their laziness).

N2: **wielkoludy** (a nonhuman giant, like in a fairy tale) and **wielkoludzi** (a tall person)



(J) Polish These Nouns (2/2)

	Plural		Plural
A	<i>kalendarze</i>	I	<i>chybcy piloci</i>
B	<i>jarskie kapelusze</i>	J	<i>czepki</i>
C	<i>łotrzy</i>	K	<i>grzejniki</i>
D	<i>robotnicy</i>	L	<i>rude groby</i>
E	<i>chorowici chirurdzy</i>	M	<i>sympansy</i>
F	<i>partnerzy</i> (but accept *partnrzy as well)	N	<i>panowie</i>
G	<i>zwaliści golfiści</i>	O	<i>załężki</i>
H	<i>zachodnioeuropejscy</i> <i>akordeoniści</i>		



(K) Two Róng's Don't Make a Right (1/1)

A1.

1. J
2. F
3. A
4. Q
5. C
6. R
7. D
8. N
9. H
10. M
11. G
12. I
13. B
14. O
15. K
16. L
17. E
18. P

- A2. ㄅ chóng ㄐ jik ㄐㄨㄛ thikúng
A3. ㄉ dan ㄌ rok ㄌㄛ ranmo

Explanation:

Writing direction is left to right.

Syllable-initial consonants are written with full letters:

ㄍ k-, ㄏ kh-, ㄔ ch-, ㄊ t-, ㄒ th-, ㄉ d-, ㄅ b-, ㄗ ts-, ㄖ r-, ㄌ l-

If there is no initial consonant, the null initial ㄍ is used instead.

Vowels are marked by symbols to the left of, below, or to the right of consonants:

ㄍ ke, ㄐ ki, ㄎ ko, ㄎ kó, ㄍ ku, ㄍ kú

If there is no vowel mark, by default the vowel *a* is used: ㄍ ka.

Syllable-final consonants are written with symbols above or to the left of the consonant-vowel block:

ㄍ kak, ㄍ kan, ㄍ kat, ㄍ kang



(L) We Were Born to Solve This Problem (1/1)

L1. They were kissed.

L2. ichemwelninwen (causative) or iwelcheminwen (transitive)

L3. See below:

Ordering

Verb template 1 (with infixes -in-, -yax-):

[obj] [ROOT] [subj] [in/yax] [“used to”]

Verb template 2 (with infix -nin-, and with no infix (-0-))

[obj] [subj] [ROOT] [nin/0] [“used to”]

Morphemes

Infixes:

0 = intransitive

-in- = transitive (“i” drops after vowel: $V_{in} \rightarrow V_n$)

-yax- = passive

-nin- = causative (a kind of transitive)

Subj:

1s: ne 1p: chem

2s: e 2p: em

3s: pe 3p: pem

Obj:

1s: ni 1p: chimi

2s: i 2p: imi

3s: pi 3p: pimi (in fact, it is “mi”, but “pimi” should be inferred from data)

“used to”:

-qal with singular subject, -wen with plural subject



(M) Colorless Green Concepts Scripting Furiously (1/2)

M1: $(E \vee (D \rightarrow ((C \rightarrow \text{not}B) \wedge \text{not}A)))$

M2: (note that iv and vi are interchangeable, but they shouldn't have the same answer. I.e., you should either have (iv = B and vi = C) or (iv = C and vi = B)

- i = A
- ii = F
- iii = D
- iv = B/C
- v = E
- vi = B/C

Solution path:

From page 1, we can figure out how the system works. I will do this by determining the representations for AND, OR, NOT, and IF/THEN; in reality, AND and OR can be further broken down, but I find it easier to treat them as atomic.

From the first one, we get OR:

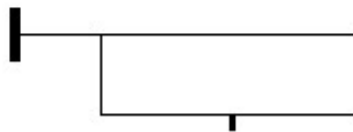

From the fifth one: Given the representation of OR above, we can factor out the $(D \vee C)$ part to get that the part at the top is $B \wedge A$, to give us AND:

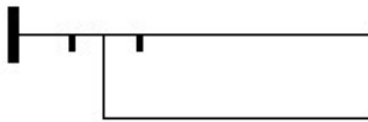

From the 2nd and the 4th ones: We can tell that the bottom part of the 2nd is $C \rightarrow B$, and the bottom part of the 4th is $C \rightarrow \text{not}B$. From that minimal pair, we get NOT:

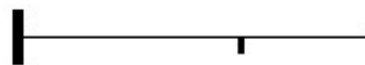

We can finally get IF/THEN from, e.g., the 2nd one:

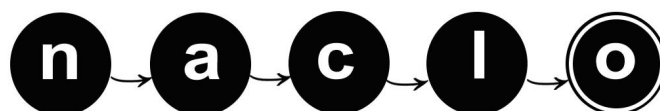

(M) Colorless Green Concepts Scripting Furiously (2/2)

Now, to solve A: We first label the lines A through E.

Looking at the outermost layer gives us $(E \vee \dots)$, where we need to fill in the ...

The next layer expands it to $(E \vee (D \rightarrow \dots))$

The next layer gives us an AND: $(E \vee (D \rightarrow (\dots \wedge \dots)))$

The bottom part of the AND is $C \rightarrow \text{not}B$. The top part is $\text{not}A$ (one of the two bars next to each other was part of the AND). So our final answer is: $(E \vee (D \rightarrow ((C \rightarrow \text{not}B) \wedge \text{not}A)))$

And to solve B:

They give us this story, so we should first construct a logical statement to represent it.

First, it says "all this only holds true if the polyverse is Groop-normal." So our formula will be "the universe is Groop-normal" \rightarrow (everything else)

All the other ones seem to be about what things are guaranteed to be galactions. So it seems like it should become: "the universe is Groop-normal" \rightarrow (... \rightarrow "x is a galaction")

Now, under what conditions is x a galaction? First, all quaxors are galactions: "the universe is Groop-normal" \rightarrow ("x is a quaxor" \rightarrow "x is a galaction")

Also, if x is a pulsoid with a sateotrope that is not dingly: "the universe is Groop-normal" \rightarrow (("x is a quaxor" \vee ("x is a pulsoid" \wedge "x has a sateotrope" \wedge not"x is dingly")) \rightarrow "x is a galaction")

Now let's look at the diagram we are given. To turn it into a logical statement:

Label the lines A through F, from top to bottom

The outmost layer gives an IF/THEN: $F \rightarrow \dots$

The next layer is also an IF/THEN, where the IF part is a bunch of stuff and the THEN is A: $F \rightarrow (\dots \rightarrow A)$

The stuff in the dots gives us an OR: $F \rightarrow ((E \vee \dots) \rightarrow A)$

The remaining dots give us an AND: $F \rightarrow ((E \vee (\dots \wedge B)) \rightarrow A)$

The final part is notD and C: $F \rightarrow ((E \vee (\text{not}D \wedge C \wedge B)) \rightarrow A)$

So this logical statement from the diagram almost maps nicely to the logical form we generated from the story. We have:

F = "the universe is Groop-normal"

E = "x is a quaxor"

D = "x is dingly")

C/B = "x has a sateotrope"/ "x is a pulsoid"

A = "x is a galaction"

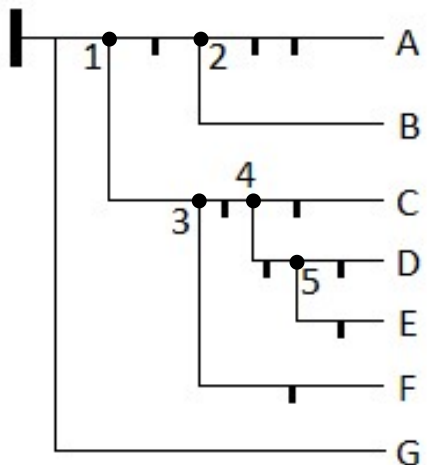

- 5. $\sim E \wedge D$
- 4. $(\sim E \wedge D) \wedge C$
- 3. $F \vee [(\sim E \wedge D) \wedge C]$
- 2. $B \wedge \sim A$
- 1. $F \vee [(\sim E \wedge D) \wedge C] \rightarrow B \wedge \sim A$
- Final: $G \rightarrow (F \vee [(\sim E \wedge D) \wedge C]) \rightarrow (B \wedge \sim A)$



(N) Fun With Witsuwit'en (1/1)

- | | |
|-------|-------|
| 1. A | 13. G |
| 2. W | 14. X |
| 3. I | 15. O |
| 4. V | 16. J |
| 5. T | 17. C |
| 6. L | 18. H |
| 7. N | 19. E |
| 8. B | 20. K |
| 9. D | 21. M |
| 10. P | 22. R |
| 11. Q | 23. S |
| 12. F | 24. U |

Notes:

bət	abdomen
bət-dəχ	abdomen-top = top of stomach
cəs	feather
dəχ	top
dəχ-yəs	top-snow = snow on branches or rooftops
dəlkw'əχ	frog
dəlkw'əχ-bət	frog-abdomen = light blue color
dəlkw'əχ-dətay	frog-duck = bat
dəlkw'əχ-neɫdəc	frog-blanket = broadleaf plantain
də-ni	male-person = man
də-ni-nin	male-person-face = penny
ɬəc	dog
ɬəc-tl'ol	dog-rope = dog harness
ləc-yəs	dog-snow = wolf
lə(c)-də-ni	dog-male-person = male dog
lə(c)-nə-ni	dog-female-person = female dog
neɫdəc	blanket
nin	face
wəq'əz	cold
wəq'əz yəs	cold-snow = fine powder snow
wəq'əz yu	cold-tooth = icicle
yəs	snow
yəscəs	snow-feather = snowflake
yu	tooth

dətay = duck, but anything like bird or wing/winged is fine
tl'ol = rope, but harness or similar is fine

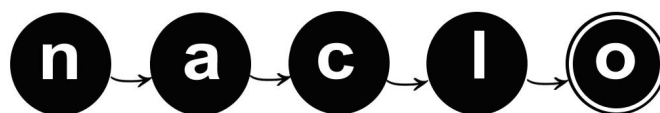

(O) Infer a Surprise (1/1)

Rule 1: If __Sentence 2__ is more than __6__ words long, label the sentences __entailment____. (Examples 8,9,13,21; any 2 of these is sufficient)

Rule 2: If __Sentence 2 is contained within Sentence 1__, label the sentences __entailment____. (Examples 6,11,15,20; any 2 of these is sufficient)

Rule 3: If __Sentence 1__ contains the word _walrus____, label the sentences __nonentailment____. (Examples 1,16,18; any 2 of these is sufficient)

From the examples, it seems that the model has given different priorities to these three rules. Rank the rules in order of priority:

TOP PRIORITY: Rule 1

MIDDLE PRIORITY: Rule 3

BOTTOM PRIORITY: Rule 2

Which test examples allow you to determine this ranking?

27: Shows Rule 1 outranks Rule 2

31: Shows Rule 3 outranks Rule 2

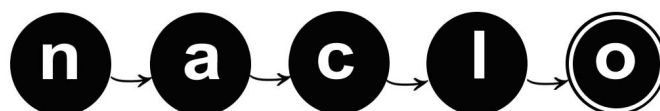

(P) Do You Hear the Master's Moon? (1/2)

Q1.

I hear a moon below you.

You shake the clam next to your owl.

We do not see your banana in front of my sons.

Q2. Note that there are three possible answers for each question.

*yangna taakitna yak yangna dakinawan balna mukusni balana kurarahwaski
yangna dakinawan balna mukusni balana yangna taakitna yak kurarahwaski
yangna dakinawan balna mukusni balana kurarahwaski yangna taakitna yak*

*wasni yaihntit yak sunilu palani yamtaman
sunilu palani wasni yaihntit yak yamtaman
sunilu palani yamtaman wasni yaihntit yak*

*minit yak pinsil balna buitayang manna titinghmana
pinsil balna minit yak buitayang manna titinghmana
pinsil balna buitayang manna titinghmana minit yak*

*pala yak yangna wakikisa balna kastasmanna
yangna wakikisa balna pala yak kastasmanna
yangna wakikisa balna kastasmanna pala yak*



(P) Do You Hear the Master's Moon? (2/2)

Q3.

- Word order is (PP) S O (PP) V (PP).
- PP can appear anywhere except between S and O.
- Pronouns are *yang, man, witing, yangna, manna, witingna*. Pronouns are dropped in the subject and object positions, but are mandatory in possessive and locative constructions.
- The definite marker and possessive markers are:
 - 1SG *-ki-*, 2SG *-ma-*, 3SG *-ni-*; 1PL *-kina-*, 2PL *-mana-*, 3P *-nina-*
 - These markers are infixes. There is no phonological rule for the location of the infixing, but instead each word has a specific location where all infixes go. For example, the word *su-lu* (dog) has all infixes placed in between the two syllables (e. g. *sunilu* = the dog, *sukilu* = my dog, etc)
 - *-ni-* also serves as the definite article ('the'). The absence of any infix is translated as the indefinite article ('a').
- Possessives are formed as follows: Possessor + Possessee. The possessee is marked as explained above.

positive negative	1st	2nd	3rd
Singular	-(ta)yang -(ta)syang	-(ta)man -(ta)sman	-wi -waski
Plural	-(ta)yangna -(ta)syangna	-(ta)manna -(ta)smanna	as 3s but with stem redupli- cation

- Verbs: in the 3rd person plural, the final syllable of the stem is reduplicated; the syllable coda/vowel length is deleted in the reduplication. The *-ta-* infix does not appear in the verbs *to hear* or *to see*.
- Locatives (PP) are formed using the same system as possessives.
 - Two location words also undergo vowel harmonising in the 2nd person (*mi-ma-t* > *mamat*, *di-ma-t* > *damat*).



(Q) A Tale of Kieu-plets (1/2)

11. Sharp: sắc, hỏi, nặng, and ngã

Flat: ngang and huyền

12. 6: *chùa, chỗ*

7: *tôn, gái*

8: *rằng, tiên*

9: correct

10: correct

11: any of the following accepted:

- *truyền*, REMOVED
- *trà*, REMOVED
- REMOVED, *giọng*

13. *từ*, BOTH, *khách*, *la*, *đà*

14.

1. The first line of the couplet must have six words; the second line, eight.

2. Even-numbered syllables must have a specific tonality:

a. Syllables 2, 6, and 8 must have **flat** (*ngang* or *huyền*) tonality.

b. Syllable 4 must have **sharp** (*sắc*, *hỏi*, *nặng*, or *ngã*) tonality.

3. Each line's sixth syllable must rhyme with the sixth syllable of the other line in the couplet.

This pattern may be represented as follows:

• b • # • b

• b • # • b • b



(Q) A Tale of Kieu-plets (2/2)

Note: Couplets 9 and 10 are authentic. Here are the errors in the other four couplets.

Note: bold marks rhymes; **red, incorrect words** (correct words given in brackets).

6. Vâng trình hội **chùa** [chủ] xem **tường**, [1/4 is not sharp; failure to rhyme]
Mà sao trong sổ đoạn **chổ** [trường] có tên.
7. Âu đàn quả **tôn** [kiếp] nhân **duyên**, [1/4 is not sharp; 2/8 is not flat]
Cùng người một hội, một **thuyền** đâu **ngái** [xa]!
8. Thưa **rằng** [rằng]: Chút phận ngâ **thơ**, [1/2 is not flat; 2/4 is not sharp]
Dưỡng sinh đôi **tiên** [nợ] tóc **ơ** chưa đều
9. Ngoài song thỏ thẻ oanh **vàng**, [Correct]
Nách tường bông liễu bay **ngang** trước màn.
10. Chàng Kim từ lại thư **song**, [Correct]
Nỗi nằng canh cánh bên **lòng** biếng khuây.
11. Mành Tương phất phất gió **truyền** [đàn], [failure to rhyme; incorr. # of syl.]
Hương gậy mùi nhớ, trà **khan** giọng **ành**.



(R) Disambiguate This! (1/2)

R1.

4. PRN
5. DET
6. DET
7. DET
8. PRN
9. PRN
10. PRN
11. PRN
12. DET
13. PRN
14. DET
15. DET

R2.

- (1) her: SELECT DET if (+1 N)
- (2) her: SELECT DET if (+1 ADJ)
- (3) her: SELECT PRN

The following ordering principle is inviolable: (3) after (1) and (2). Otherwise order is flexible.

Alternate solution:

- (1) as above
- (2) her: SELECT DET if (+2 N)
- (3) as above

R3.

11. I give her flowers. 1 point for identifying the sentence correctly 3 points for explanation 1 point for identifying ambiguity in the use of 'her' 1 point for identifying why 'her' is categorized as a DET 1 point for identifying the importance of the meaning of 'give'

R4.

- (1) PRN/DET: SELECT DET if (-1 PREP)
- (2) PRN/DET: SELECT DET if (-1 [VRB]) and (+1 [N])
- (3) PRN/DET: SELECT PRN
- (4) N/VRB: SELECT N if (-1 DET)
- (5) N/VRB: SELECT VRB



(R) Disambiguate This! (2/2)

R4 continued:

The following ordering principles are inviolable:

(3) after (1) and (2),

(4) after (1) and (2),

(5) after (4).

Otherwise order is flexible.

Alternate solution:

(1) N/VRB: SELECT N if (-2 [VRB])

(2) N/VRB: SELECT N if (-2 PREP)

(3) N/VRB: SELECT VRB

(4) DET/PRN: SELECT DET if (+1 N)

(5) DET/PRN: SELECT PRN Ordering principles are as above.

